

XV Servo Motors

The new XV Servo Motor line from Emerson Control Techniques is billed as delivering high-performance, low inertia, and high torque in a compact motor package. It offers a low cost solution with the features of a premium priced servo offering. Intended for higher throughputs and smaller machines, XV motors are available in 4 Frame Sizes: 40, 60, 80 and 130 mm with speeds ranging from 2000 to 5000 RPM.

Applications with Continuous Torque requirements up to 101-in (11.4 Nm) are the perfect match for the XV motors. They are IP55 or IP65 rated and CE, UL and ROHS approved.



XV Servo Motor Overview

Motor Model	XV
AC Supply Voltage	240
Frame	40mm,60mm,80mm,130mm
Flange	METRIC
Continuous Torque	Up to 101 lb-in (11.4Nm)
Peak Torque	Up to 304 lb-in (34Nm)
Rated Torque/Speed	Up to 101 lb-in (11.4Nm)
Maximum Rated Speeds	2000, 3000, 5000 RPM
Brake	Optional
Connectorized	Standard
Flying Lead	2 ft (Standard on 40-80mm)
Inertia	Low - Medium
Encoder Resolution	2048 lines/rev
Insulation Class	Class F, EN 60034-1
Temperature	N/A
Ingress Protection	IP55, IP65
Approvals	CE, UL, ROHS

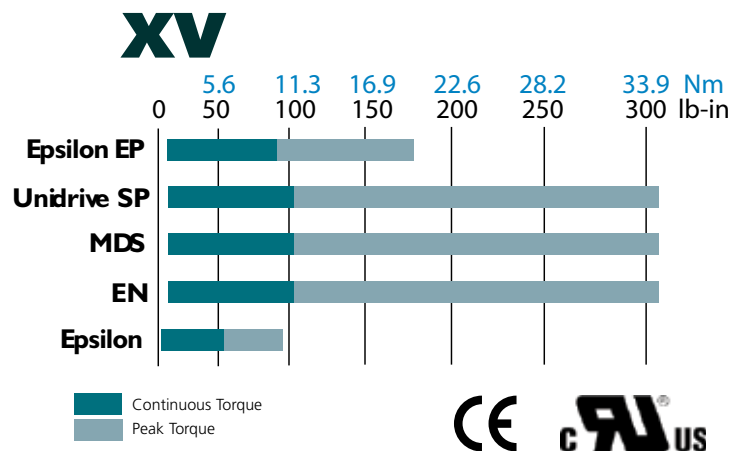



XV Motor Specifications

Motor Model	Rated Torque lb-in (Nm)	Peak Torque lb-in (Nm)	Rated Power (KW)	Stall Current (Arms)	Motor Resistance (Ohms)	Motor Inductance (mH)	Operating Speed (RPM) Max	Inertia (lb-in-sec ²) (kg-cm ²)	Motor Ke (Vrms/ krpm)	Motor Kt (lb-in/Arms) (Nm/Arms)	Motor Weight lb kg
XV-401	0.84 0.095	2.39 0.27	0.03	1.07	11.69	8.54	5000	0.0000097 0.011	7.8	0.89 0.10	0.70 0.32
XV-402	1.41 0.159	3.98 0.45	0.05	1.20	9.43	8.27	5000	0.0000186 0.021	10.6	1.28 0.14	0.84 0.38
XV-403	2.81 0.318	7.70 0.87	0.1	1.38	6.89	6.73	5000	0.0000398 0.045	12.7	2.24 0.25	1.10 0.50
XV-604	2.81 0.318	8.41 0.95	0.1	1.65	2.50	7.37	5000	0.0001009 0.114	13.6	1.86 0.21	1.81 0.82
XV-606	5.64 0.637	16.1 1.82	0.2	1.63	4.15	15.21	5000	0.0001611 0.182	29.2	3.76 0.42	2.38 1.08
XV-6011	11.3 1.27	32.3 3.65	0.4	2.89	1.64	7.32	5000	0.0002841 0.321	29.5	4.15 0.47	3.48 1.58
XV-8017	16.9 1.91	48.6 5.49	0.6	3.58	1.43	9.18	5000	0.0009664 1.092	35.2	5.00 0.57	5.55 2.52
XV-8022	22.6 2.55	62.8 7.10	0.8	4.83	0.87	5.94	5000	0.0013355 1.509	35.6	4.94 0.56	7.00 3.18
XV-8023	23.3 2.63	67.1 7.58	0.55	3.82	1.29	9.10	3000	0.0013355 1.509	44.6	6.32 0.71	7.00 3.18
XV-8028	28.2 3.19	81.1 9.16	1	5.37	0.75	5.04	5000	0.0017054 1.927	39.2	5.57 0.63	8.59 3.90
XV-13042	42.2 4.77	123.0 13.90	1.5	8.23	0.41	4.11	5000	0.0106112 11.99	38.6	5.35 0.61	16.6 7.54
XV-13046	46.5 5.25	137.2 15.50	1.1	6.28	0.77	7.76	3000	0.0106112 11.99	53.1	7.71 0.87	16.6 7.54
XV-13051	50.6 5.72	147.8 16.70	0.6	4.15	1.87	20.10	2000	0.0106112 11.99	85.8	12.87 1.45	16.6 7.54
XV-13068	67.5 7.63	199.1 22.50	1.6	9.23	0.47	5.27	3000	0.0152040 17.18	54.2	7.59 0.86	21.3 9.68
XV-13089	88.8 10.0	260.2 29.40	0.9	5.78	1.41	15.99	2000	0.0152040 17.18	94.6	15.57 1.76	21.3 9.68
XV-130101	101 11.5	296.5 33.50	1.2	7.63	0.87	10.67	2000	0.0200718 22.68	90.00	13.88 1.57	25.9 11.8

XV Holding Brake Specifications

Motor Frame Size	Power Supply (VDC)	Current (A)	Static Torque (lb-in) (Nm)	Mechanical Engagement Time (ms)	Added Inertia (lb-in-sec ²) (kg-cm ²)	Added Weight (kg)
40	24	0.25	2.8 0.318	20	0.000003 0.003	0.2
60	24	0.283	13.0 1.47	30	0.000018 0.02	0.6
80	24	0.52	28.6 3.23	50	0.000066 0.075	0.7
130	24	0.81	92.0 10.4	50	0.000478 0.54	0.83

XV- Servomotor Speed Torque Curves

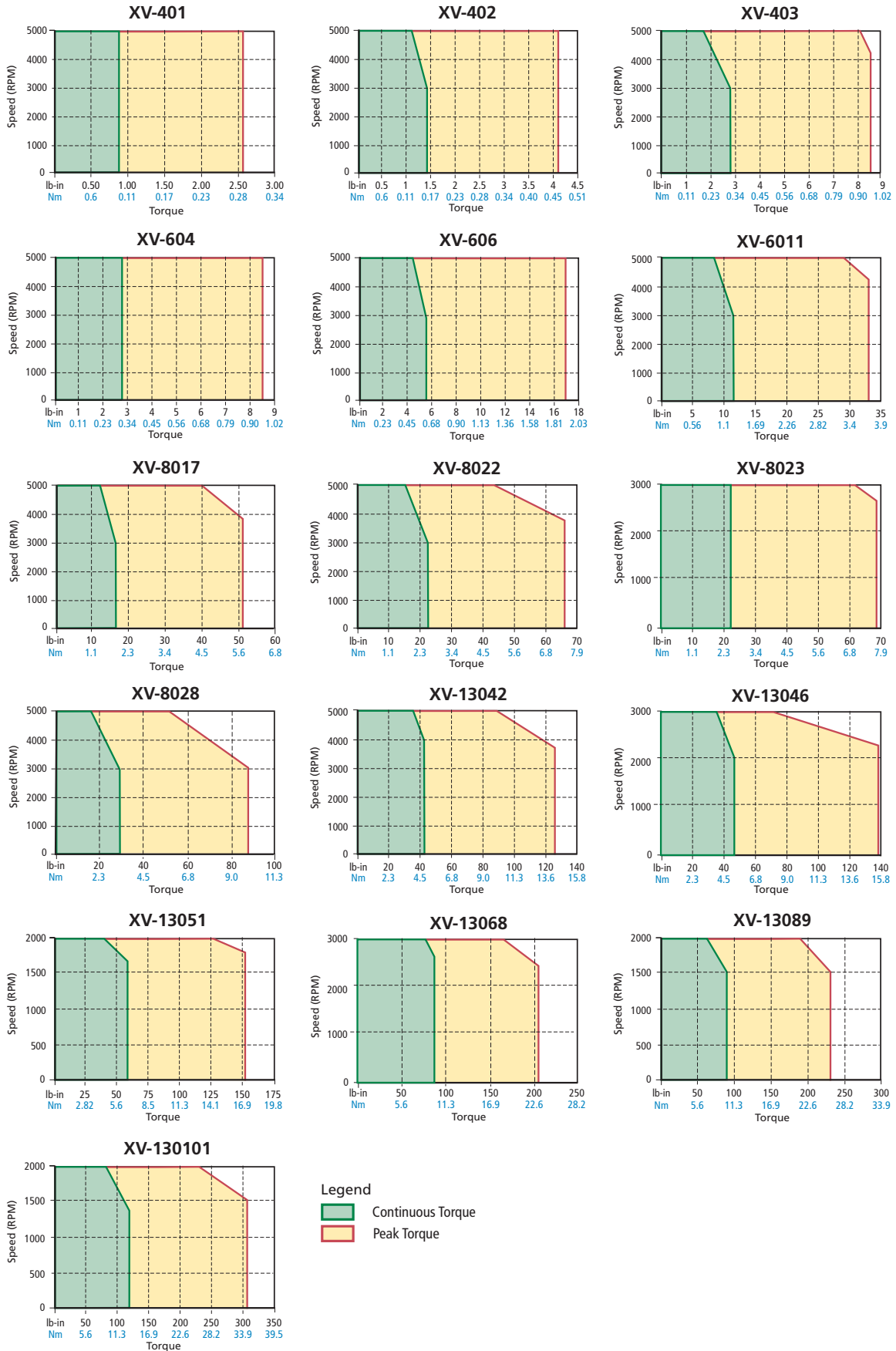

Epsilon EP Servo Drive Cable Selection

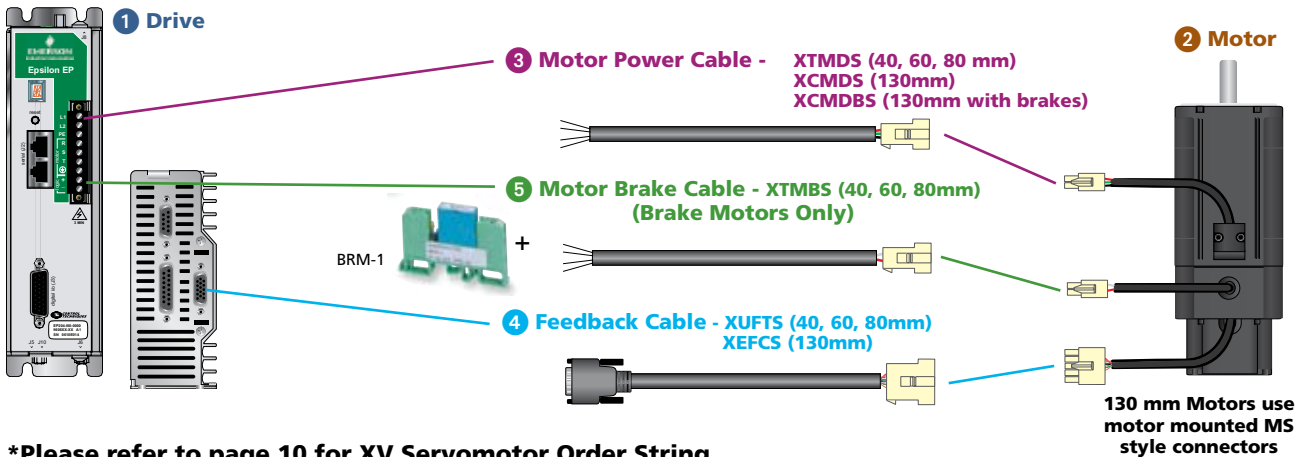

*Please refer to page 10 for XV Servomotor Order String.

1 Epsilon EP Servo Drive (x = B, I, P)	2 XV Servo Motor*	3 Motor Power Cable (xxx=feet)	4 Feedback Cable (xxx=feet)	5 Motor Brake Cable* (required w/ all brake motors) (xxx=feet)
EP202-X00-EN000	XVM-401-TONS-0000 XVM-401-TBNS-0000	XTMS-xxx XTMS-xxx	XUFTS-xxx XUFTS-xxx	XTBMS-xxx
EP202-X00-EN000	XVM-402-TONS-0000 XVM-402-TBNS-0000	XTMS-xxx XTMS-xxx	XUFTS-xxx XUFTS-xxx	XTBMS-xxx
EP202-X00-EN000	XVM-403-TONS-0000 XVM-403-TBNS-0000	XTMS-xxx XTMS-xxx	XUFTS-xxx XUFTS-xxx	XTBMS-xxx
EP202-X00-EN000	XVM-604-TONS-0000 XVM-604-TBNS-0000	XTMS-xxx XTMS-xxx	XUFTS-xxx XUFTS-xxx	XTBMS-xxx
EP202-X00-EN000	XVM-606-TONS-0000 XVM-606-TBNS-0000	XTMS-xxx XTMS-xxx	XUFTS-xxx XUFTS-xxx	XTBMS-xxx
EP204-X00-EN000	XVM-6011-TONS-0000 XVM-6011-TBNS-0000	XTMS-xxx XTMS-xxx	XUFTS-xxx XUFTS-xxx	XTBMS-xxx
EP204-X00-EN000	XVM-8017-TONS-0000 XVM-8017-TBNS-0000	XTMS-xxx XTMS-xxx	XUFTS-xxx XUFTS-xxx	XTBMS-xxx
EP204-X00-EN000	XVM-8022-TONS-0000 XVM-8022-TBNS-0000	XTMS-xxx XTMS-xxx	XUFTS-xxx XUFTS-xxx	XTBMS-xxx
EP204-X00-EN000	XVM-8023-TONS-0000 XVM-8023-TBNS-0000	XTMS-xxx XTMS-xxx	XUFTS-xxx XUFTS-xxx	XTBMS-xxx
EP206-X00-EN000	XVM-8017-TONS-0000 XVM-8017-TBNS-0000	XTMS-xxx XTMS-xxx	XUFTS-xxx XUFTS-xxx	XTBMS-xxx
EP206-X00-EN000	XVM-8022-TONS-0000 XVM-8022-TBNS-0000	XTMS-xxx XTMS-xxx	XUFTS-xxx XUFTS-xxx	XTBMS-xxx
EP206-X00-EN000	XVM-8023-TONS-0000 XVM-8023-TBNS-0000	XTMS-xxx XTMS-xxx	XUFTS-xxx XUFTS-xxx	XTBMS-xxx
EP206-X00-EN000	XVM-8028-TONS-0000 XVM-8028-TBNS-0000	XTMS-xxx XTMS-xxx	XUFTS-xxx XUFTS-xxx	XTBMS-xxx
EP206-X00-EN000	XVM-13046-CONS-0000 XVM-13046-CBNS-0000	XCMS-xxx XCMSB-xxx **	XEFC-xxx XEFC-xxx	
EP206-X00-EN000	XVM-13051-CONS-0000 XVM-13051-CBNS-0000	XCMS-xxx XCMSB-xxx **	XEFC-xxx XEFC-xxx	
EP206-X00-EN000	XVM-13089-CONS-0000 XVM-13089-CBNS-0000	XCMS-xxx XCMSB-xxx **	XEFC-xxx XEFC-xxx	

** Combination Motor Power and Brake Cable

MDS

Cable Selection

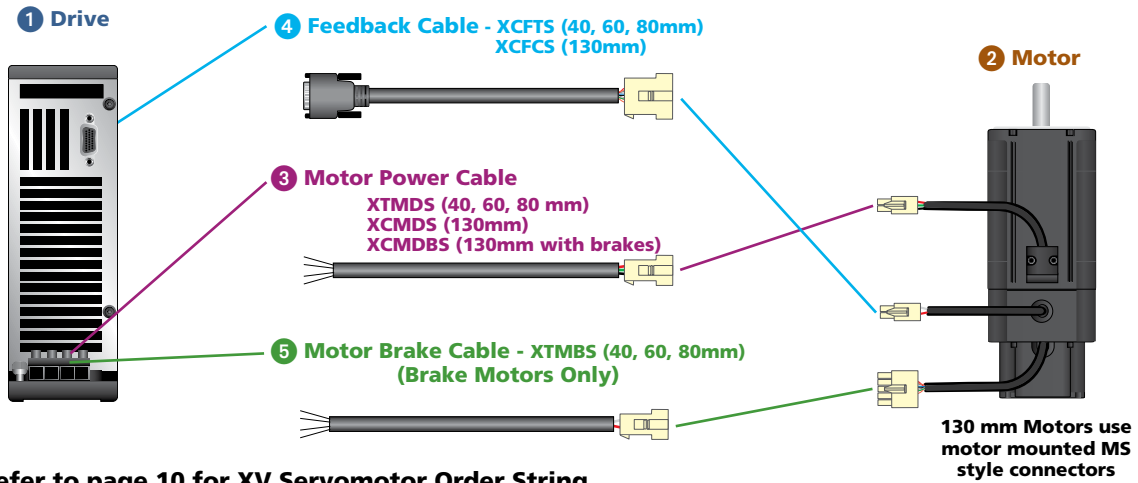

*Please refer to page 10 for XV Servomotor Order String.

1 MDS Servo Drive	2 XV Servo Motor*	3 Motor Power Cable (xxx=feet)	4 Feedback Cable (xxx=feet)	5 Motor Brake Cable (required w/ all brake motors) (xxx=feet)
MD-404-00-000	XVM-6011-TONS-0000 XVM-6011-TBNS-0000	XTMDS-xxx XTMDS-xxx	XCFTS-xxx XCFTS-xxx	XTBMS-xxx
MD-404-00-000	XVM-8017-TONS-0000 XVM-8017-TBNS-0000	XTMDS-xxx XTMDS-xxx	XCFTS-xxx XCFTS-xxx	XTBMS-xxx
MD-404-00-000	XVM-8022-TONS-0000 XVM-8022-TBNS-0000	XTMDS-xxx XTMDS-xxx	XCFTS-xxx XCFTS-xxx	XTBMS-xxx
MD-404-00-000	XVM-8023-TONS-0000 XVM-8023-TBNS-0000	XTMDS-xxx XTMDS-xxx	XCFTS-xxx XCFTS-xxx	XTBMS-xxx
MD-404-00-000	XVM-13051-CONS-0000 XVM-13051-CBNS-0000	XCMDs-xxx XCMDBS-xxx **	XCFCs-xxx XCFCs-xxx	
MD-407-00-00	XVM-8017-TONS-0000 XVM-8017-TBNS-0000	XTMDS-xxx XTMDS-xxx	XCFTS-xxx XCFTS-xxx	XTBMS-xxx
MD-407-00-00	XVM-8022-TONS-0000 XVM-8022-TBNS-0000	XTMDS-xxx XTMDS-xxx	XCFTS-xxx XCFTS-xxx	XTBMS-xxx
MD-407-00-00	XVM-8023-TONS-0000 XVM-8023-TBNS-0000	XTMDS-xxx XTMDS-xxx	XCFTS-xxx XCFTS-xxx	XTBMS-xxx
MD-407-00-00	XVM-8028-TONS-0000 XVM-8028-TBNS-0000	XTMDS-xxx XTMDS-xxx	XCFTS-xxx XCFTS-xxx	XTBMS-xxx
MD-407-00-00	XVM-13042-CONS-0000 XVM-13042-CBNS-0000	XCMDs-xxx XCMDBS-xxx **	XCFCs-xxx XCFCs-xxx	
MD-407-00-00	XVM-13046-CONS-0000 XVM-13046-CBNS-0000	XCMDs-xxx XCMDBS-xxx **	XCFCs-xxx XCFCs-xxx	
MD-407-00-00	XVM-13051-CONS-0000 XVM-13051-CBNS-0000	XCMDs-xxx XCMDBS-xxx **	XCFCs-xxx XCFCs-xxx	
MD-407-00-00	XVM-13089-CONS-0000 XVM-13089-CBNS-0000	XCMDs-xxx XCMDBS-xxx **	XCFCs-xxx XCFCs-xxx	
MD-407-00-00	XVM-130101-CONS-0000 XVM-130101-CBNS-0000	XCMDs-xxx XCMDBS-xxx **	XCFCs-xxx XCFCs-xxx	
MD-410-00-000	XVM-8028-TONS-0000 XVM-8028-TBNS-0000	XTMDS-xxx XTMDS-xxx	XCFTS-xxx XCFTS-xxx	XTBMS-xxx
MD-410-00-000	XVM-13042-CONS-0000 XVM-13042-CBNS-0000	XCMDs-xxx XCMDBS-xxx **	XCFCs-xxx XCFCs-xxx	
MD-410-00-000	XVM-13046-CONS-0000 XVM-13046-CBNS-0000	XCMDs-xxx XCMDBS-xxx **	XCFCs-xxx XCFCs-xxx	
MD-410-00-000	XVM-13068-CONS-0000 XVM-13068-CBNS-0000	XCMDs-xxx XCMDBS-xxx **	XCFCs-xxx XCFCs-xxx	
MD-410-00-000	XVM-13089-CONS-0000 XVM-13089-CBNS-0000	XCMDs-xxx XCMDBS-xxx **	XCFCs-xxx XCFCs-xxx	
MD-410-00-000	XVM-130101-CONS-0000 XVM-130101-CBNS-0000	XCMDs-xxx XCMDBS-xxx **	XCFCs-xxx XCFCs-xxx	

** Combination Motor Power and Brake Cable

Unidrive SP

Cable Selection

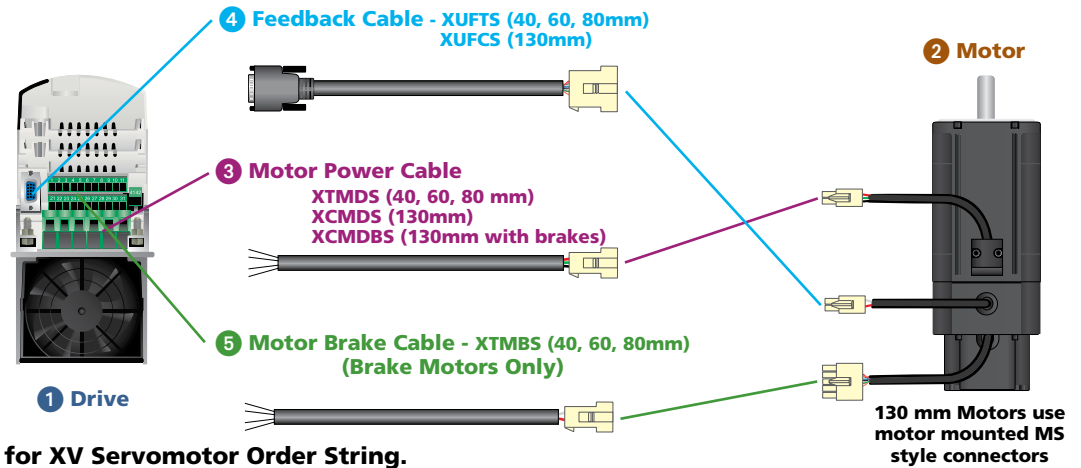

*Please refer to page 10 for XV Servomotor Order String.

1 Unidrive SP	2 XV Servo Motor*	3 Motor Power Cable (xxx=feet)	4 Feedback Cable (xxx=feet)	5 Motor Brake Cable (required w/ all brake motors) (xxx=feet)
SP1201	XVM-6011-TONS-0000 XVM-6011-TBNS-0000	XTMDS-xxx XTMDS-xxx	XUFTS-xxx XUFTS-xxx	XTBMS-xxx
SP1201	XVM-8017-TONS-0000 XVM-8017-TBNS-0000	XTMDS-xxx XTMDS-xxx	XUFTS-xxx XUFTS-xxx	XTBMS-xxx
SP1201	XVM-8022-TONS-0000 XVM-8022-TBNS-0000	XTMDS-xxx XTMDS-xxx	XUFTS-xxx XUFTS-xxx	XTBMS-xxx
SP1201	XVM-8023-TONS-0000 XVM-8023-TBNS-0000	XTMDS-xxx XTMDS-xxx	XUFTS-xxx XUFTS-xxx	XTBMS-xxx
SP1201	XVM-8028-TONS-0000 XVM-8028-TBNS-0000	XTMDS-xxx XTMDS-xxx	XUFTS-xxx XUFTS-xxx	XTBMS-xxx
SP1201	XVM-13051-CONS-0000 XVM-13051-CBNS-0000	XCMDs-xxx XCMDBS-xxx **	XUFCS-xxx XUFCS-xxx	
SP1202	XVM-8017-TONS-0000 XVM-8017-TBNS-0000	XTMDS-xxx XTMDS-xxx	XUFTS-xxx XUFTS-xxx	XTBMS-xxx
SP1202	XVM-8022-TONS-0000 XVM-8022-TBNS-0000	XTMDS-xxx XTMDS-xxx	XUFTS-xxx XUFTS-xxx	XTBMS-xxx
SP1202	XVM-8023-TONS-0000 XVM-8023-TBNS-0000	XTMDS-xxx XTMDS-xxx	XUFTS-xxx XUFTS-xxx	XTBMS-xxx
SP1202	XVM-8028-TONS-0000 XVM-8028-TBNS-0000	XTMDS-xxx XTMDS-xxx	XUFTS-xxx XUFTS-xxx	XTBMS-xxx
SP1202	XVM-13046-CONS-0000 XVM-13046-CBNS-0000	XCMDs-xxx XCMDBS-xxx **	XUFCS-xxx XUFCS-xxx	
SP1202	XVM-13051-CONS-0000 XVM-13051-CBNS-0000	XCMDs-xxx XCMDBS-xxx **	XUFCS-xxx XUFCS-xxx	
SP1202	XVM-13089-CONS-0000 XVM-13089-CBNS-0000	XCMDs-xxx XCMDBS-xxx **	XUFCS-xxx XUFCS-xxx	
SP1203	XVM-8022-TONS-0000 XVM-8022-TBNS-0000	XTMDS-xxx XTMDS-xxx	XUFTS-xxx XUFTS-xxx	XTBMS-xxx
SP1203	XVM-8023-TONS-0000 XVM-8023-TBNS-0000	XTMDS-xxx XTMDS-xxx	XUFTS-xxx XUFTS-xxx	XTBMS-xxx
SP1203	XVM-8028-TONS-0000 XVM-8028-TBNS-0000	XTMDS-xxx XTMDS-xxx	XUFTS-xxx XUFTS-xxx	XTBMS-xxx
SP1203	XVM-13042-CONS-0000 XVM-13042-CBNS-0000	XCMDs-xxx XCMDBS-xxx **	XUFCS-xxx XUFCS-xxx	
SP1203	XVM-13046-CONS-0000 XVM-13046-CBNS-0000	XCMDs-xxx XCMDBS-xxx **	XUFCS-xxx XUFCS-xxx	
SP1203	XVM-13051-CONS-0000 XVM-13051-CBNS-0000	XCMDs-xxx XCMDBS-xxx **	XUFCS-xxx XUFCS-xxx	
SP1203	XVM-13068-CONS-0000 XVM-13068-CBNS-0000	XCMDs-xxx XCMDBS-xxx **	XUFCS-xxx XUFCS-xxx	
SP1203	XVM-13089-CONS-0000 XVM-13089-CBNS-0000	XCMDs-xxx XCMDBS-xxx **	XUFCS-xxx XUFCS-xxx	
SP1203	XVM-130101-CONS-0000 XVM-130101-CBNS-0000	XCMDs-xxx XCMDBS-xxx **	XUFCS-xxx XUFCS-xxx	
SP1204	XVM-8028-TONS-0000 XVM-8028-TBNS-0000	XTMDS-xxx XTMDS-xxx	XUFTS-xxx XUFTS-xxx	XTBMS-xxx
SP1204	XVM-13042-CONS-0000 XVM-13042-CBNS-0000	XCMDs-xxx XCMDBS-xxx **	XUFCS-xxx XUFCS-xxx	
SP1204	XVM-13046-CONS-0000 XVM-13046-CBNS-0000	XCMDs-xxx XCMDBS-xxx **	XUFCS-xxx XUFCS-xxx	
SP1204	XVM-13068-CONS-0000 XVM-13068-CBNS-0000	XCMDs-xxx XCMDBS-xxx **	XUFCS-xxx XUFCS-xxx	
SP1204	XVM-13089-CONS-0000 XVM-13089-CBNS-0000	XCMDs-xxx XCMDBS-xxx **	XUFCS-xxx XUFCS-xxx	
SP1204	XVM-130101-CONS-0000 XVM-130101-CBNS-0000	XCMDs-xxx XCMDBS-xxx **	XUFCS-xxx XUFCS-xxx	

** Combination Motor Power and Brake Cable

Epsilon Cable Selection

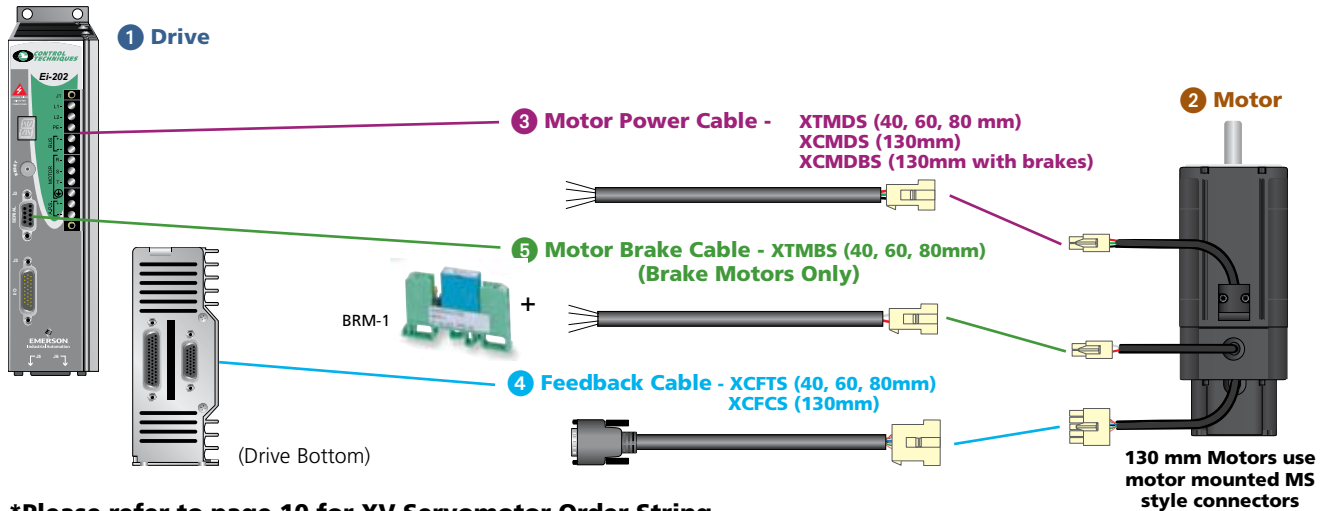

*Please refer to page 10 for XV Servomotor Order String.

1 Epsilon Servo Drive (E=Eb, Ei or Ei-DN)	2 XV Servo Motor*	3 Motor Power Cable (xxx=feet)	4 Feedback Cable (xxx=feet)	5 Motor Brake Cable* (required w/ all brake motors) (xxx=feet)
ε-202-00-000	XVM-401-TONS-0000 XVM-401-TBNS-0000	XTMDS-xxx XTMDS-xxx	XCFTS-xxx XCFTS-xxx	XTBMS-xxx
ε-202-00-000	XVM-402-TONS-0000 XVM-402-TBNS-0000	XTMDS-xxx XTMDS-xxx	XCFTS-xxx XCFTS-xxx	XTBMS-xxx
ε-202-00-000	XVM-403-TONS-0000 XVM-403-TBNS-0000	XTMDS-xxx XTMDS-xxx	XCFTS-xxx XCFTS-xxx	XTBMS-xxx
ε-202-00-000	XVM-606-TONS-0000 XVM-606-TBNS-0000	XTMDS-xxx XTMDS-xxx	XCFTS-xxx XCFTS-xxx	XTBMS-xxx
ε-203-00-000	XVM-606-TONS-0000 XVM-606-TBNS-0000	XTMDS-xxx XTMDS-xxx	XCFTS-xxx XCFTS-xxx	XTBMS-xxx
ε-203-00-000	XVM-6011-TONS-0000 XVM-6011-TBNS-0000	XTMDS-xxx XTMDS-xxx	XCFTS-xxx XCFTS-xxx	XTBMS-xxx
ε-203-00-000	XVM-8017-TONS-0000 XVM-8017-TBNS-0000	XTMDS-xxx XTMDS-xxx	XCFTS-xxx XCFTS-xxx	XTBMS-xxx
ε-205-00-000	XVM-6011-TONS-0000 XVM-6011-TBNS-0000	XTMDS-xxx XTMDS-xxx	XCFTS-xxx XCFTS-xxx	XTBMS-xxx
ε-205-00-000	XVM-8017-TONS-0000 XVM-8017-TBNS-0000	XTMDS-xxx XTMDS-xxx	XCFTS-xxx XCFTS-xxx	XTBMS-xxx
ε-205-00-000	XVM-8022-TONS-0000 XVM-8022-TBNS-0000	XTMDS-xxx XTMDS-xxx	XCFTS-xxx XCFTS-xxx	XTBMS-xxx
ε-205-00-000	XVM-8023-TONS-0000 XVM-8023-TBNS-0000	XTMDS-xxx XTMDS-xxx	XCFTS-xxx XCFTS-xxx	XTBMS-xxx
ε-205-00-000	XVM-8028-TONS-0000 XVM-8028-TBNS-0000	XTMDS-xxx XTMDS-xxx	XCFTS-xxx XCFTS-xxx	XTBMS-xxx
ε-205-00-000	XVM-13051-CONS-0000 XVM-13051-CBNS-0000	XCMS-xxx XCMSDBS-xxx**	XCFC-xxx XCFC-xxx	

** Combination Motor Power and Brake Cable

EN Series Cable Selection

1 Drive

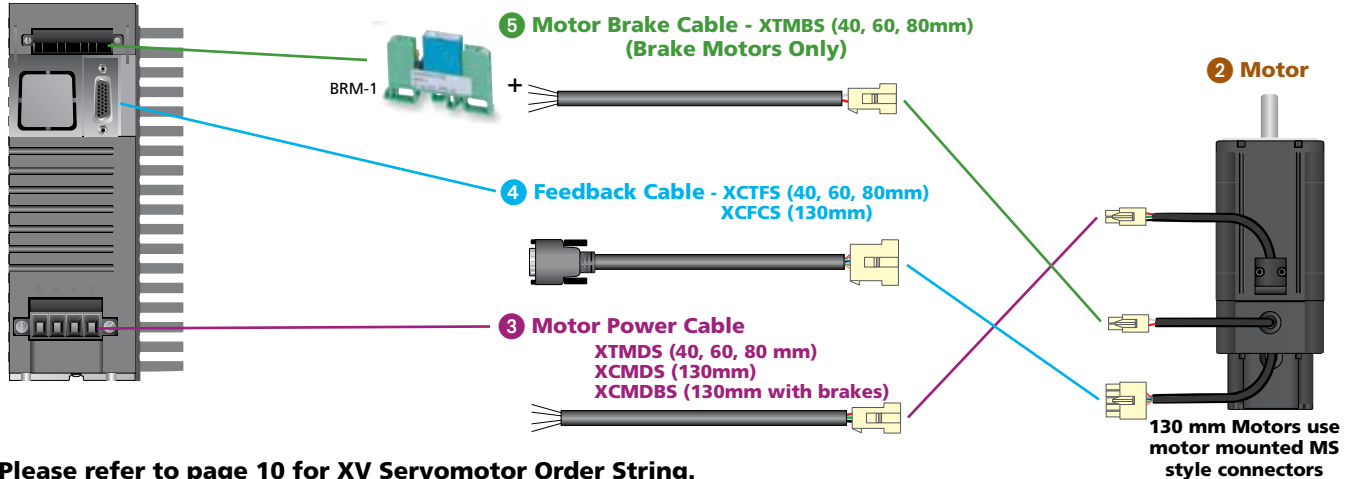

*Please refer to page 10 for XV Servomotor Order String.

1 EN Servo Drive	2 XV Servo Motor*	3 Motor Power Cable (xxx=feet)	4 Feedback Cable (xxx=feet)	5 Motor Brake Cable (required w/ all brake motors) (xxx=feet)
EN-204-00-000	XVM-6011-TONS-0000 XVM-6011-TBNS-0000	XTMS-xxx XTMS-xxx	XCFES-xxx XCFES-xxx	XTBMS-xxx
EN-204-00-000	XVM-8017-TONS-0000 XVM-8017-TBNS-0000	XTMS-xxx XTMS-xxx	XCFES-xxx XCFES-xxx	XTBMS-xxx
EN-204-00-000	XVM-8022-TONS-0000 XVM-8022-TBNS-0000	XTMS-xxx XTMS-xxx	XCFES-xxx XCFES-xxx	XTBMS-xxx
EN-204-00-000	XVM-8023-TONS-0000 XVM-8023-TBNS-0000	XTMS-xxx XTMS-xxx	XCFES-xxx XCFES-xxx	XTBMS-xxx
EN-204-00-000	XVM-8028-TONS-0000 XVM-8028-TBNS-0000	XTMS-xxx XTMS-xxx	XCFES-xxx XCFES-xxx	XTBMS-xxx
EN-204-00-000	XVM-13051-CONS-0000 XVM-13051-CBNS-0000	XCMS-xxx XCMSBS-xxx **	XCFCS-xxx XCFCS-xxx	
EN-208-00-000	XVM-8022-TONS-0000 XVM-8022-TBNS-0000	XTMS-xxx XTMS-xxx	XCFES-xxx XCFES-xxx	XTBMS-xxx
EN-208-00-000	XVM-8028-TONS-0000 XVM-8028-TBNS-0000	XTMS-xxx XTMS-xxx	XCFES-xxx XCFES-xxx	XTBMS-xxx
EN-208-00-000	XVM-13042-CONS-0000 XVM-13042-CBNS-0000	XCMS-xxx XCMSBS-xxx **	XCFCS-xxx XCFCS-xxx	
EN-208-00-000	XVM-13046-CONS-0000 XVM-13046-CBNS-0000	XCMS-xxx XCMSBS-xxx **	XCFCS-xxx XCFCS-xxx	
EN-208-00-000	XVM-13068-CONS-0000 XVM-13068-CBNS-0000	XCMS-xxx XCMSBS-xxx **	XCFCS-xxx XCFCS-xxx	
EN-208-00-000	XVM-13089-CONS-0000 XVM-13089-CBNS-0000	XCMS-xxx XCMSBS-xxx **	XCFCS-xxx XCFCS-xxx	
EN-208-00-000	XVM-130101-CONS-0000 XVM-130101-CBNS-0000	XCMS-xxx XCMSBS-xxx **	XCFCS-xxx XCFCS-xxx	
EN-214-00-000	XVM-13042-CONS-0000 XVM-13042-CBNS-0000	XCMS-xxx XCMSBS-xxx **	XCFCS-xxx XCFCS-xxx	
EN-214-00-000	XVM-13068-CONS-0000 XVM-13068-CBNS-0000	XCMS-xxx XCMSBS-xxx **	XCFCS-xxx XCFCS-xxx	
EN-214-00-000	XVM-13089-CONS-0000 XVM-13089-CBNS-0000	XCMS-xxx XCMSBS-xxx **	XCFCS-xxx XCFCS-xxx	
EN-214-00-000	XVM-130101-CONS-0000 XVM-130101-CBNS-0000	XCMS-xxx XCMSBS-xxx **	XCFCS-xxx XCFCS-xxx	

** Combination Motor Power and Brake Cable

XV Servomotor Order String



XV M - xxx xxx - x x N S - 0000

| Special Options
 | S = Standard
 | N = Incremental Encoder
 | Brake Option:
 | B = with brake
 | O = without brake
 | Connector Type:
 | T = Flying Lead with Connectors
 | C = MS Connectors
 | Continuous Torque (lb-in): 1, 2, 3, 4, 6, 11, 17,
 | 22, 23, 28, 42, 46, 51, 68, 89, or 101
 | Frame Size (mm): 40, 60, 80 or 130
 | Metric Mounting Flange
 | XV Servo Motor Family

XV- Servomotor Dimensional Drawings

40, 60, 80 mm

Fly lead length 12" on 40mm, 60mm and 80mm

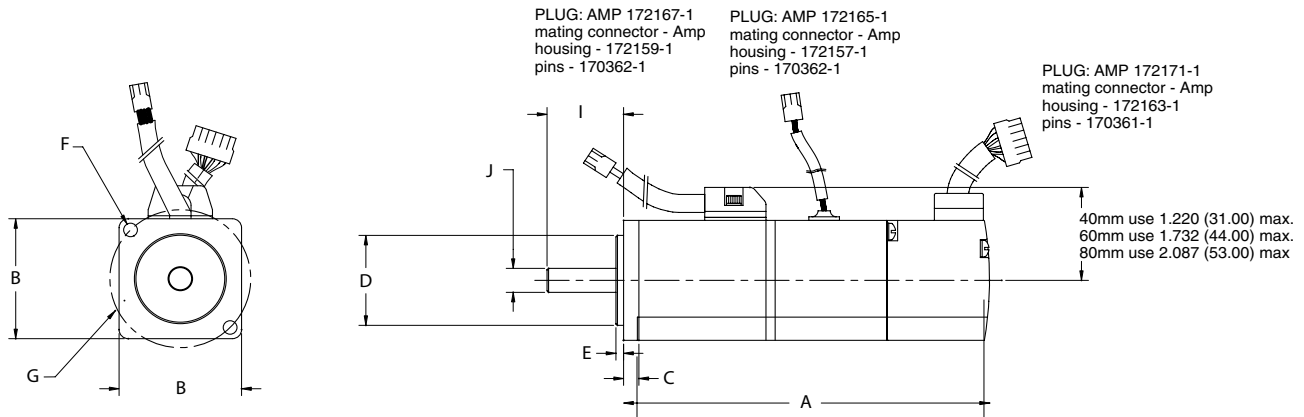

130 mm

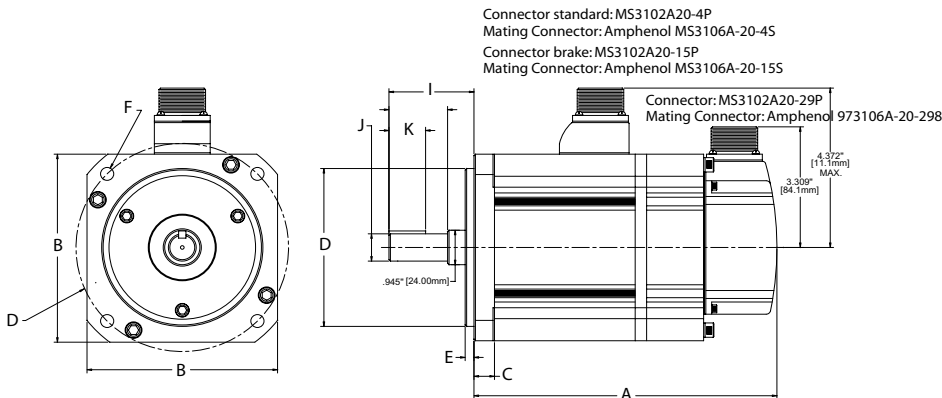

Keyway Dimensions

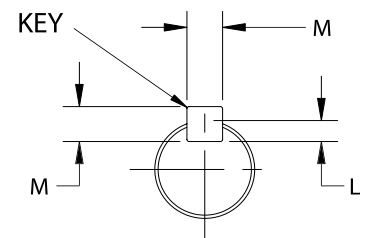

XV Servomotor Dimensions

Inches (mm)	40mm			60MM		
	XVM-401	XVM-402	XVM-403	XVM-604	XVM-606	XVM-6011
A Length Overall - CONS (Max)						
A Length Overall - TONS (Max)	2.980 (75.7)	3.248 (82.5)	3.917 (99.5)	3.622 (92)	4.173 (106)	5.276 (134)
A Length Overall - CBNS (Max)						
A Length Overall - TBNS (Max)	4.409 (112)	4.685 (119)	5.354 (136)	5.197 (132)	5.748 (146)	6.850 (174)
B Flange Square	1.575 (40)	1.575 (40)	1.575 (40)	2.44 (62)	2.44 (62)	2.44 (62)
C Flange Thickness	0.197 (5)	0.197 (5)	0.197 (5)	0.236 (6)	0.236 (6)	0.236 (6)
D Pilot Diameter	1.181 (30)	1.181 (30)	1.181 (30)	1.969 (50)	1.969 (50)	1.969 (50)
E Pilot Thickness	0.098 (2.5)	0.098 (2.5)	0.098 (2.5)	0.118 (3)	0.118 (3)	0.118 (3)
F Bolt Hole Diameter	0.177 (4.5)	0.177 (4.5)	0.177 (4.5)	0.236 (6)	0.236 (6)	0.236 (6)
G Bolt Circle Diameter	1.811 (46)	1.811 (46)	1.811 (46)	2.756 (70)	2.756 (70)	2.756 (70)
H Signal Connector Height - CONS (Max)						
H Signal Connector Height - TONS (Max)	1.220 (31)	1.220 (31)	1.220 (31)	1.732 (44)	1.732 (44)	1.732 (44)
H Signal Connector Height - CBNS (Max)						
H Signal Connector Height - TBNS (Max)	1.220 (31)	1.220 (31)	1.220 (31)	1.732 (44)	1.732 (44)	1.732 (44)
I Shaft Length	0.984 (25)	0.984 (25)	0.984 (25)	1.181 (30)	1.181 (30)	1.181 (30)
J Shaft Diameter	0.315 (8)	0.315 (8)	0.315 (8)	0.551 (14)	0.551 (14)	0.551 (14)
Shaft key Dimensions						
K Keyway Length (Min)				0.886 (22.5)	0.886 (22.5)	0.886 (22.5)
L Keyway Depth				0.118 (3)	0.118 (3)	0.118 (3)
M Keyway Width				0.197 (5)	0.197 (5)	0.197 (5)

Inches (mm)	80MM				130MM					
	XVM-8017	XVM-8022	XVM-8023	XVM-8028	XVM-13042	XVM-13046	XVM-13051	XVM-13068	XVM-13089	XVM-130101
A Length Overall - CONS (Max)					6.614 (168)	6.614 (168)	6.614 (168)	7.559 (192)	7.559 (192)	8.501 (216)
A Length Overall - TONS (Max)	5.433 (138)	6.220 (158)	6.220 (158)	7.008 (178)						
A Length Overall - CBNS (Max)					8.110 (206)	8.110 (206)	8.110 (206)	9.055 (230)	9.055 (230)	10.00 (254)
A Length Overall - TBNS (Max)	7.008 (178)	7.795 (198)	7.795 (198)	8.583 (218)						
B Flange Square	3.150 (80)	3.150 (80)	3.150 (80)	3.150 (80)	5.118 (130)	5.118 (130)	5.118 (130)	5.118 (130)	5.118 (130)	5.118 (130)
C Flange Thickness	0.433 (11)	0.433 (11)	0.433 (11)	0.433 (11)	0.551 (14)	0.551 (14)	0.551 (14)	0.551 (14)	0.551 (14)	0.551 (14)
D Pilot Diameter	2.756 (70)	2.756 (70)	2.756 (70)	2.756 (70)	4.331 (110)	4.331 (110)	4.331 (110)	4.331 (110)	4.331 (110)	4.331 (110)
E Pilot Thickness	0.118 (3)	0.118 (3)	0.118 (3)	0.118 (3)	0.236 (6)	0.236 (6)	0.236 (6)	0.236 (6)	0.236 (6)	0.236 (6)
F Bolt Hole Diameter	0.260 (6.6)	0.260 (6.6)	0.260 (6.6)	0.260 (6.6)	0.354 (9)	0.354 (9)	0.354 (9)	0.354 (9)	0.354 (9)	0.354 (9)
G Bolt Circle Diameter	3.543 (90)	3.543 (90)	3.543 (90)	3.543 (90)	5.709 (145)	5.709 (145)	5.709 (145)	5.709 (145)	5.709 (145)	5.709 (145)
H Signal Connector Height - CONS (Max)					4.409 (112)	4.409 (112)	4.409 (112)	4.409 (112)	4.409 (112)	4.409 (112)
H Signal Connector Height - TONS (Max)	2.087 (53)	2.087 (53)	2.087 (53)	2.087 (53)						
H Signal Connector Height - CBNS (Max)					4.409 (112)	4.409 (112)	4.409 (112)	4.409 (112)	4.409 (112)	4.409 (112)
H Signal Connector Height - TBNS (Max)	2.087 (53)	2.087 (53)	2.087 (53)	2.087 (53)						
I Shaft Length	1.575 (40)	1.575 (40)	1.575 (40)	1.575 (40)	2.283 (58)	2.283 (58)	2.283 (58)	2.283 (58)	2.283 (58)	2.283 (58)
J Shaft Diameter	0.630 (16)	0.630 (16)	0.630 (16)	0.630 (16)	0.748 (19)	0.748 (19)	0.748 (19)	0.866 (22)	0.866 (22)	0.866 (22)
Shaft key Dimensions										
K Keyway Length (Min)	1.181 (30)	1.181 (30)	1.181 (30)	1.181 (30)	0.984 (25)	0.984 (25)	0.984 (25)	0.984 (25)	0.984 (25)	0.984 (25)
L Keyway Depth	0.118 (3)	0.118 (3)	0.118 (3)	0.118 (3)	0.118 (3)	0.118 (3)	0.118 (3)	0.138 (3.5)	0.138 (3.5)	0.138 (3.5)
M Keyway Width	0.197 (5)	0.197 (5)	0.197 (5)	0.197 (5)	0.197 (5)	0.197 (5)	0.197 (5)	0.236 (6)	0.236 (6)	0.236 (6)

Driving Technology...

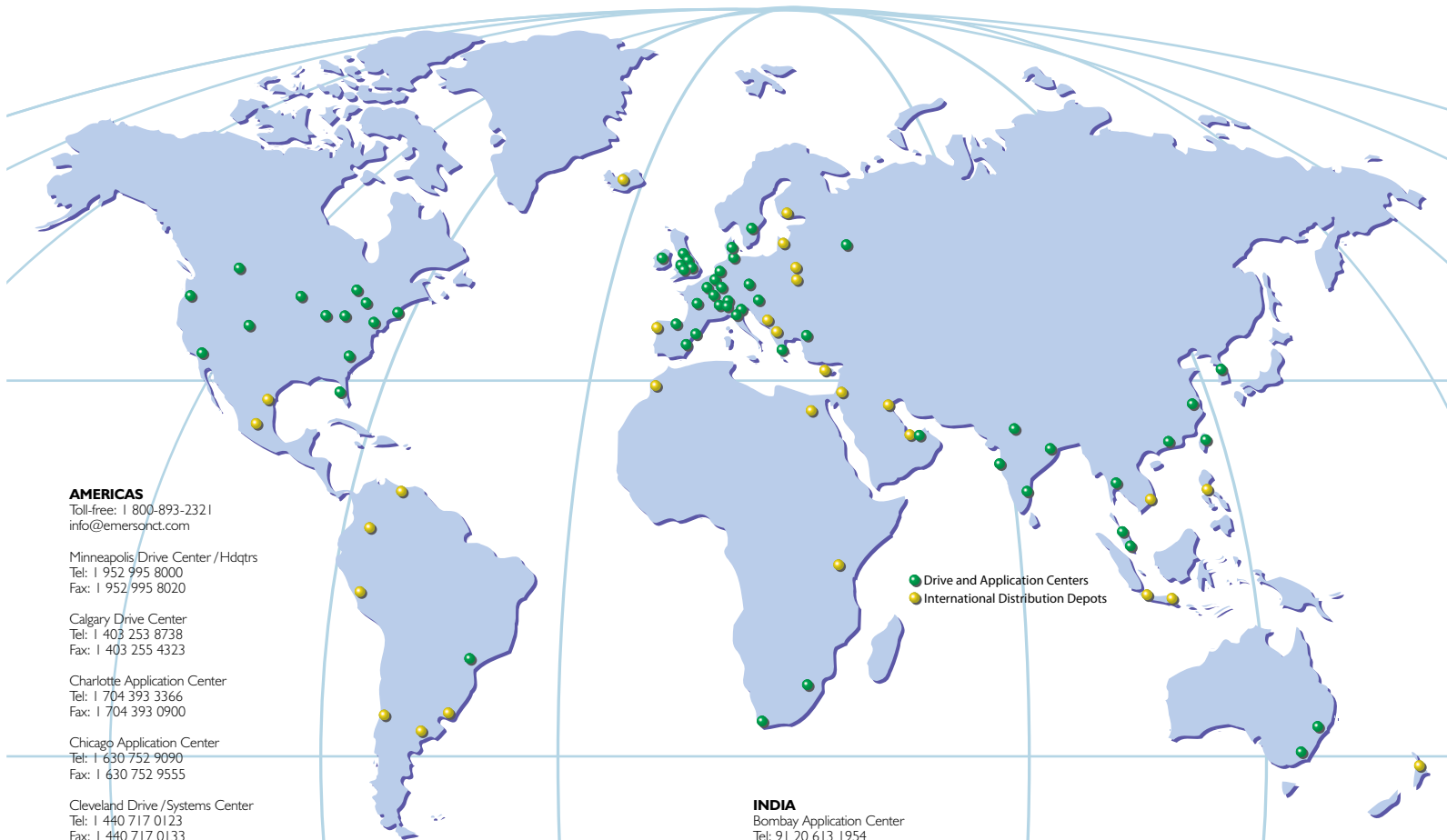

● Drive and Application Centers
● International Distribution Depots

AMERICAS

Toll-free: 1 800-893-2321
info@emersonct.com

Minneapolis Drive Center /Hdqtrs
Tel: 1 952 995 8000
Fax: 1 952 995 8020

Calgary Drive Center
Tel: 1 403 253 8738
Fax: 1 403 255 4323

Charlotte Application Center
Tel: 1 704 393 3366
Fax: 1 704 393 0900

Chicago Application Center
Tel: 1 630 752 9090
Fax: 1 630 752 9555

Cleveland Drive /Systems Center
Tel: 1 440 717 0123
Fax: 1 440 717 0133

Fort Myers Drive /Systems Center
Tel: 1 239 693 7200
Fax: 1 239 693 2431

Grand Island, N.Y., Technical Support and Service Center
Tel: 1 716 774 1193
Fax: 1 716 774 8327
After Hours: 1 716 553 2690

Latin America Sales Office
Tel: 1 305 818 8897
Fax: 1 305 818 8888
alfredo.rivas@emersonct.com

Los Angeles Drive Center
Tel: 1 562 943 0300
Fax: 1 562 902 9360

Portland Drive Center
Tel: 1 503 266 2094
Fax: 1 503 266 1152

Providence Drive Center
Tel: 1 401 541 7277
Fax: 1 401 541 7266

Toronto Application Center
Tel: 1 905 201 4699
Fax: 1 905 201 4694

Salt Lake City Drive Center
Tel: 1 801 566 5521
Fax: 1 801 566 5673

Sao Paulo Application Center
Tel: 55 11 3618 6569
Fax: 55 11 9283 1778

York, Pa., Drive Center
Tel: 1 717 751 4200
Fax: 1 717 751 4263

AUSTRALIA

Melbourne Application Center
A.C.N. 003 815 281
Tel: 61 973 81777
Fax: 61 9729 3200
After Hours: 61 2 9963 5271

Sydney Drive Center
A.C.N. 003 815 281
Tel: 61 2 9838 7222
Fax: 61 2 9838 7764
After Hours: 61 2 9963 5271

AUSTRIA

Linz Drive Center
Tel: 43 7229 789480
Fax: 43 7229 7894810
After Hours: 43 7215 3502

BELGIUM

Brussels Drive Center
Tel: 32 2725 2721
Fax: 32 2725 4940

CHINA

Shanghai Drive Center
Tel: 86 21 64085747
Fax: 86 21 64083282

Beijing Application Center
Tel: 86 10 6592 5321 ext 20
Fax: 86 10 6500 3094

CZECH REPUBLIC

Brno Drive Center
Tel: 420 541 192111
Fax: 420 541 192115
After Hours: 420 541 192 119

DENMARK

Copenhagen Drive Center
Tel: 45 4369 6100
Fax: 45 4369 6101
After Hours: 45 4369 6100

FRANCE

Angoulême Drive Center
Tel: 33 5 4564 5454
Fax: 33 5 4564 5400

GERMANY

Bonn Drive Center
Tel: 49 2242 8770
Fax: 49 2242 877277
After Hours: 49 1714 964777

IRELAND

Dublin Drive Center
Tel: 353 45 433044
Fax: 353 45 433622

ITALY

Milan Drive Center and Reggio Emilia Application Center
Tel: 39 02575 751
Fax: 39 02575 12858
After Hours: 39 02575 751

GREECE

Athens Application Center
Tel: 0030 210 57 86086/088
Fax: 0030 210 57 86087

HOLLAND

Rotterdam Drive Center
Tel: 31 1844 20555
Fax: 31 1844 20721
After Hours: 31 1844 20555

HONG KONG

Hong Kong Application Center
Tel: 852 2979 5271
Fax: 852 2979 5220

INDIA

Bombay Application Center
Tel: 91 20 613 1954
Fax: 91 20 612 3771

Calcutta Application Center
Tel: 91 33 357 5302/357 5306
Fax: 91 33 357 3435
After Hours: 91 33 358 3622

Madras Drive Center
Tel: 91 44 4961 123/4961 130/4961083
Fax: 91 44 4961602
After Hours: 91 44 496 1083

New Delhi Application Center
Tel: 91 11 576 4782
Fax: 91 11 576 4782

IRELAND

Dublin Drive Center
Tel: 353 45 433044
Fax: 353 45 433622

ITALY

Milan Drive Center and Reggio Emilia Application Center
Tel: 39 02575 751
Fax: 39 02575 12858
After Hours: 39 02575 751

Vicenza Drive Center
Tel: 39 0444 396200
Fax: 39 0444 341317

KOREA

Seoul Application Center
Tel: 82 2 557 7374
Fax: 82 2 557 7301
After Hours: 82 2 557 7374

MALAYSIA

Kuala Lumpur Drive Center
Tel: 60 3734 9776
Fax: 60 3733 9592
After Hours: 60 12 333 8355

REPUBLIC OF SOUTH AFRICA

Johannesburg Drive Center
Tel: 27 11 462 1740
Fax: 27 11 462 1941
After Hours: 27 11 462 1740

Cape Town Application Center
Tel: 27 21 556 0245
Fax: 27 21 556 2574
After Hours: 27 11 462 1740

RUSSIA

Moscow Application Center
Tel: 7 095 232 9472
Fax: 7 095 956 4862

SINGAPORE

Singapore Drive Center
Tel: 65 271 6377
Fax: 65 272 1302
After Hours: 65 9752 5828
or 65 9636 0323

SPAIN

Barcelona Drive Center
Tel: 34 93 680 1661
Fax: 34 93 680 0903
/34 93 680 2823
After Hours: 34 610 554540

Bilbao Application Center
Tel: 34 94 620 3646
Fax: 34 94 681 1406

Valencia Drive Center
Tel: 34 96 154 2900
Fax: 34 96 153 2906

SWEDEN

Stockholm Application Center
Tel: 46 8 554 24100
Fax: 46 8 554 24120

SWITZERLAND

Lausanne Application Center
Tel: 41 21 634 0408
Fax: 41 21 635 8596
After Hours: 41 79 357 8683

Zurich Drive Center
Tel: 41 56 201 4242
Fax: 41 56 201 4243
After Hours: 41 79 357 8683

TAIWAN

Taipei Application Center
Tel: 886 22325 9555
Fax: 886 22705 9131

THAILAND

Bangkok Drive Center
Tel: 66 2580 7644
Fax: 66 2591 4559
A/Hours Sales: 66 1443 4095
A/Hours Service: 66 1443 4098

TURKEY

Istanbul Drive Center
Tel: 90 216 4182420
Fax: 90 216 4182423
After Hours: 90 216 418 2420

UAE

Dubai Application Center
Tel: 971 4 883 8650
Fax: 971 4 883 8651

UNITED KINGDOM

Telford Drive Center
Tel: 44 1952 213700
Fax: 44 1952 213701
After Hours: 44 1952 213700



EMERSON[™]
Industrial Automation

XV Servo Motors

High Value, Low Cost Solution
Performance to 100 lb-in



www.emersonct.com